

# CamBelt

## Low Profile Portable Rail Unloaders

High Capacity,  
Economical  
Unloading and Elevating

The CamBelt Portable Car Unloader takes bulk materials of all types from under a hopper car and elevates them at a 60-degree incline to standard discharge heights up to 15' 7".

It is ideally suited for applications where the use of permanent equipment in a pit beneath the rail is not practical. Its portability and low profile configuration enable the inlet to be positioned in the very restricted space between the rail and the bottom of the hopper car discharge port.

A unique nubbed conveyor belt exclusive to CamBelt conveyors, enables unloading and elevating with the same piece of equipment. The belt and material are propelled through a completely enclosed housing which eliminates problems related to dust control, product loss, and inclement weather. The CamBelt car unloader is suitable for unloading a wide variety of products, including pellets, granules, and very fine powders, regardless of flowability. It will accept materials up to 3/4" maximum particle size and will handle very fragile products with a minimum of degradation.





Model 1210 Cambelt Portable Railcar Unloader transferring material from railcar to bucket elevator inlet hopper.

## CamBelt Portable Rail Car Unloaders ®

The CamBelt Portable Car Unloader is available in two standard sized: Model 1210, which has a twelve-inch-wide belt and a capacity of up to 1,600 cubic feet per hour, and the new twenty-four-inch-wide Model 2410 with a 3,500 cubic feet per hour capacity. Both models are available in standard discharge heights of 6' 11", 13', and 15' 7". Non-standard and higher discharge heights are available.

Standard equipment includes electric drive with OSHA-approved belt guard, swivel mounted pneumatic tires, castors, quick-removable covers over tail and turn pulleys, and adjustable butterfly gates at inlet to regulate flow.

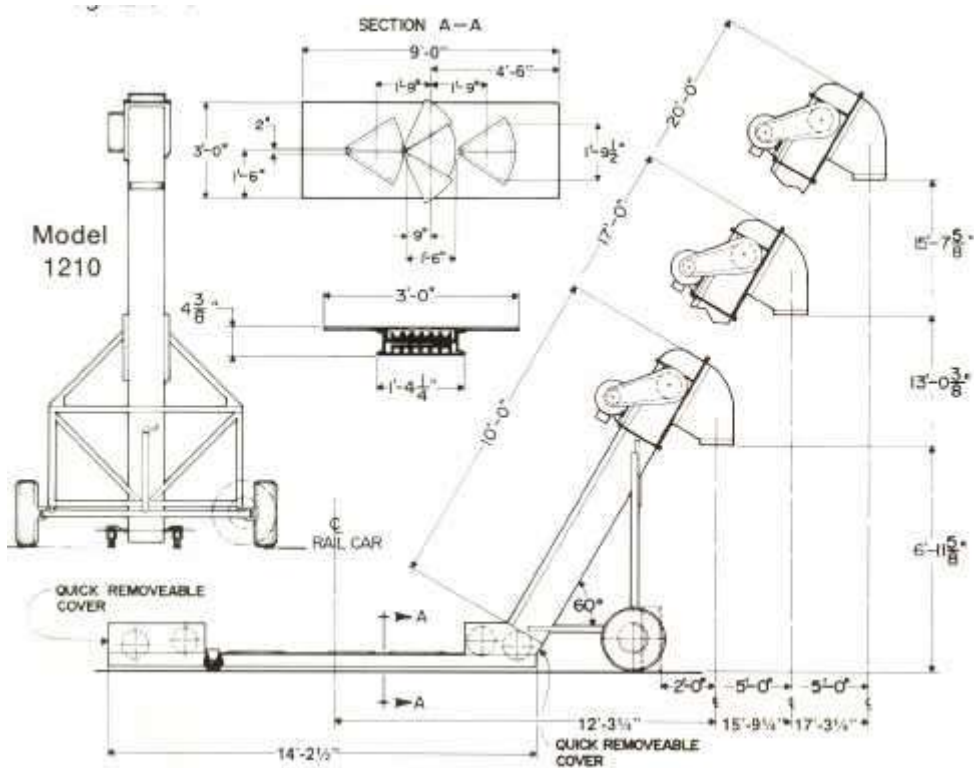



Model 1210 Portable Railcar Unloader unloading talc from railcar to be used in manufacture of roofing shingles. Replaces conventional bag handling operation.



Exclusive nubbed CamBelt conveyor belt gives high incline capability. Model 1210 (shown) has one-inch-high-nubs and flanges.



Low profile inlet positions between rail and discharge port. Swivel wheels and castors provide for lateral movement beneath car.